

MASCOT



**High End
Technology**

**Tight
Shutoff**



Reliability

**Expertise you
can trust**

GFLO General Service Control Valves





GFLO Specifications

Body type:	Globe, Angle, 3 Way, Jacketed
Size:	0.5" to 30.0"
Pressure Class:	ANSI CL150 to ANSI CL4500
End Connections:	Separable Flange, Integral Flange, RTJ, Screwed, Socketweld, Butt weld
Body Material:	Carbon Steel, Chrome Moly, 316SS, 304SS, Duplex SS, Monel, Hastelloy B&C, Zirconium, Titanium
Trim Material:	316SS, 304SS, Alloy 6, 416SS, 440SS, Bronze, Monel 400, Alloy 20, Duplex SS, Hastelloy B & C, Inconel, Zirconium, Titanium, Tungsten Carbide, Ceramic
Shut off class:	Class IV, Class V and Class VI
Characteristics:	Equal Percentage, Linear and Quick Open
Air Pressure:	2.0 to 10.0 Bar
Rangeability:	50:1
Gland Packing:	PTFE V Ring, Braided PTFE, Grafoil, Low Fugitive Emission
Special Trims:	CAVFLO, MEGAFLO, GFLO VC, MEGAFLO Plates
Actuator:	Pneumatic Spring Cylinder / Electric / Hydraulic
Positioner:	High Performance Analogue & Digital

GFLO Components

1	Body
12	Yoke Half Ring
20	Seat Ring
30	Seat Retainer
40	Bonnet (Standard)
50	Plug
55	Seat Ring Gasket
58	Bonnet Gasket
70	Bonnet Flange
76	Yoke Clamp
80	Gland Flange
82	Guide Liner Lower
83	Guide Retainer Lower
86	Guide Liner Upper
87	Guide Retainer Upper
88	Packing
93	Packing Spacer
108	Stud
114	Nut
201	Yoke
202	Cylinder
210	Adjusting Screw
211	Actuator Stem
213	Stroke Plate
225	Piston
227	Spring Button
228	Actuator Stem Spacer
229	Spring
248	Adjusting Screw Gasket
249	Stem Clamp
253	Yoke Bush
256	Retaining Ring
271	Piston O-Ring
272	Piston Stem O-Ring
274	Yoke O-Ring
275	Actuator Stem O-Ring
348	Actuator Stem Lock Nut

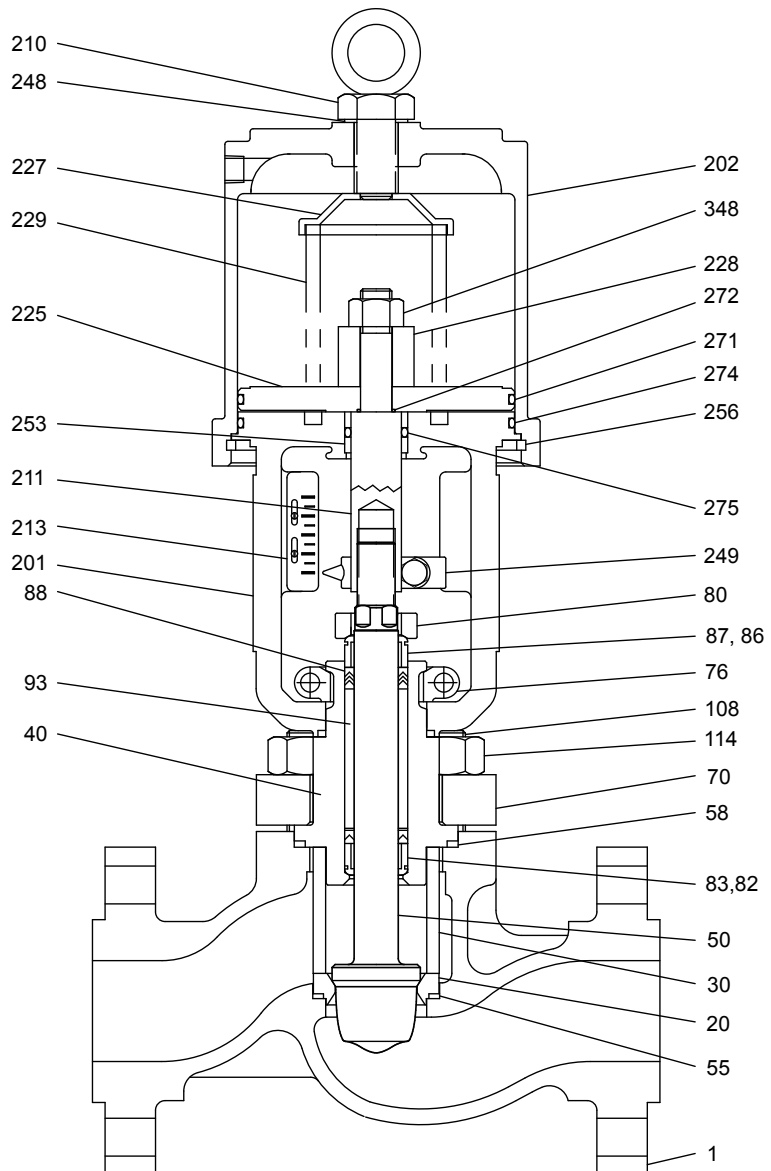



GFLO Features

Design Features

- Rugged heavy duty industrial control valve
- Proven and accepted design
- High thrust cylinder actuator
- Exceptionally tight shutoff
- Extended MTBPM
- Ease of maintenance
- High degree of spare part interchangeability
- Lowest total life cycle cost

Extended MTBPM

- High thrust cylinder actuator
- Self aligning seat ring
- Knife edge contact between plug and seat
- Exceptionally tight shutoff
- Erosion and wear of trim caused by seat leakage is greatly reduced or eliminated
- Double top stem guiding
- Large clearance between plug and retainer
- Trim will not seize or stick even in dirty service

Ease of Maintenance

- Top entry design
- Clamped in seat ring
- Minimal spare part requirements
- High degree of parts interchangeability between valve sizes and pressure ratings
- Actuators are field reversible from fail closed to open and vice versa
- Three actuator sizes typically cover 95% of all actuator requirements for both fail open and fail closed



GFLO Body Styles

- Globe
- Angle
- 3-Way

Interchangeability

CL150, CL300, CL600

- A CL600 body is used for CL150 and CL300 service for valve sizes 0.5" thru 4.0"
- End flanges are machined to suit required pressure class

CL900, CL1500

- A CL1500 body is used for CL900 service
- End flanges are machined to suit required pressure class

Benefits

- CL150 & CL300 GFLO valves are more rugged as they are designed to meet CL600 requirements
- CL900 GFLO valves are more rugged as they are designed to meet CL1500 requirements
- Spare part interchangeability between pressure ratings results in fewer spare part requirements

GFLO Angle Body

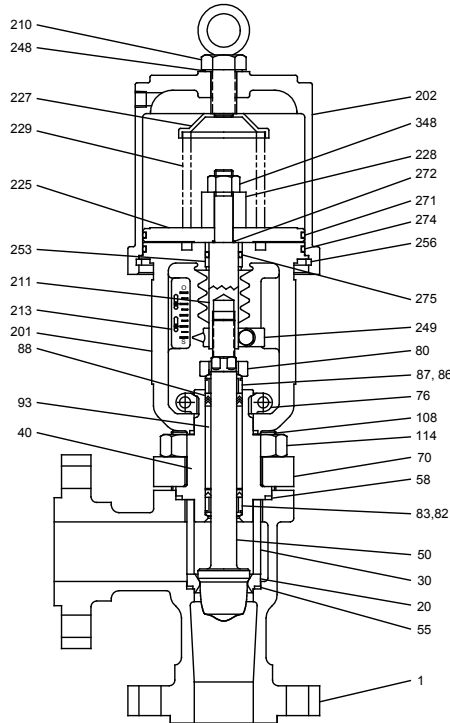

348	ACTUATOR STEM LOCK NUT
275	ACTUATOR STEM O-RING
274	YOKE O-RING
272	PISTON STEM O-RING
271	PISTON O-RING
256	RETAINING RING
253	YOKE BUSH
249	STEM CLAMP
248	ADJUSTING SCREW GASKET
229	SPRING
228	ACTUATOR STEM SPACER
227	SPRING BUTTON
225	PISTON
213	STROKE PLATE
211	ACTUATOR STEM
210	ADJUSTING SCREW
202	CYLINDER
201	YOKE
114	NUT
108	STUD
93	PACKING SPACER
88	PACKING
87	GUIDE RETAINER UPPER
86	GUIDE LINER UPPER
83	GUIDE RETAINER LOWER
82	GUIDE LINER LOWER
80	GLAND FLANGE
76	YOKE CLAMP
70	BONNET FLANGE
58	BONNET GASKET
55	SEAT RING GASKET
50	PLUG
40	BONNET
30	SEAT RETAINER
20	SEAT RING
1	BODY
ITEM NO.	PART NAME

GFLO 3-Way Body

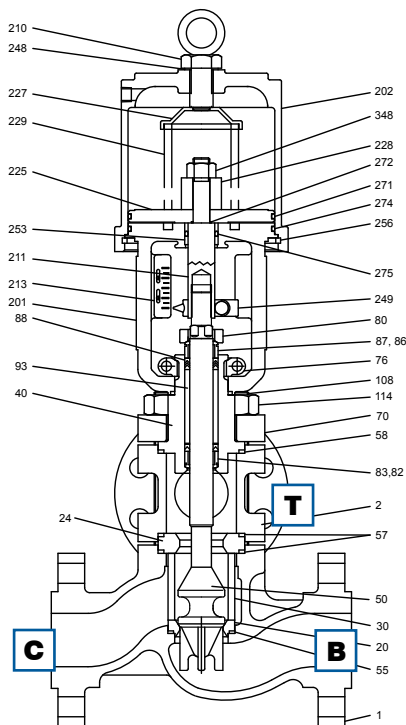

348	ACTUATOR STEM LOCK NUT
275	ACTUATOR STEM O-RING
274	YOKE O-RING
272	PISTON STEM O-RING
271	PISTON O-RING
256	RETAINING RING
253	YOKE BUSH
249	STEM CLAMP
248	ADJUSTING SCREW GASKET
229	SPRING
228	ACTUATOR STEM SPACER
227	SPRING BUTTON
225	PISTON
213	STROKE PLATE
211	ACTUATOR STEM
210	ADJUSTING SCREW
202	CYLINDER
201	YOKE
114	NUT
108	STUD
93	PACKING SPACER
88	PACKING
87	GUIDE RETAINER UPPER
86	GUIDE LINER UPPER
83	GUIDE RETAINER LOWER
82	GUIDE LINER LOWER
80	GLAND FLANGE
76	YOKE CLAMP
70	BONNET FLANGE
58	BONNET GASKET
57	SEAT RING GASKET
55	SEAT RING GASKET
50	PLUG
40	BONNET
30	SEAT RETAINER
24	UPPER SEAT RING
20	SEAT RING
2	THREE WAY ADAPTER
1	BODY
ITEM NO.	PART NAME

Diverging



Converging





GFLO End Connections

Integral Flange

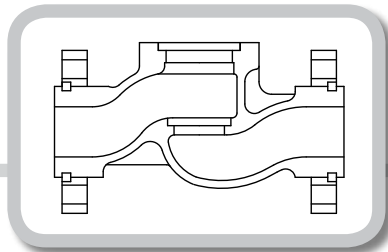
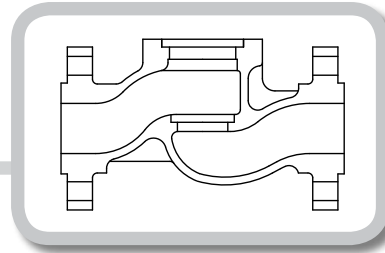

Separable Flange

RTJ

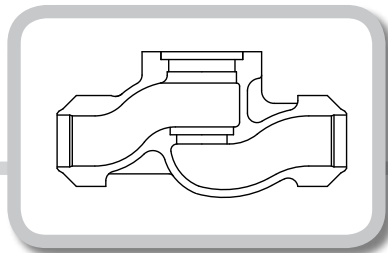
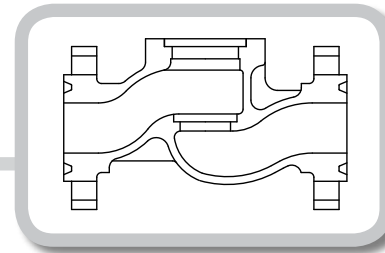

Butt Weld

Socket Weld

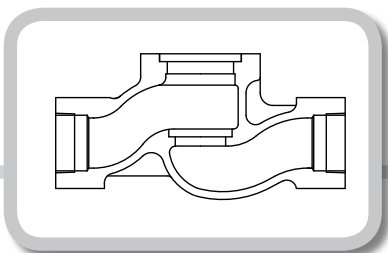
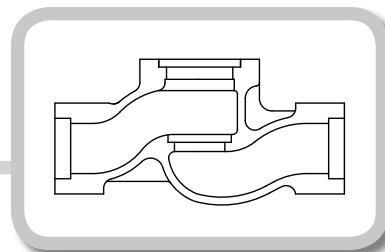

Screwed

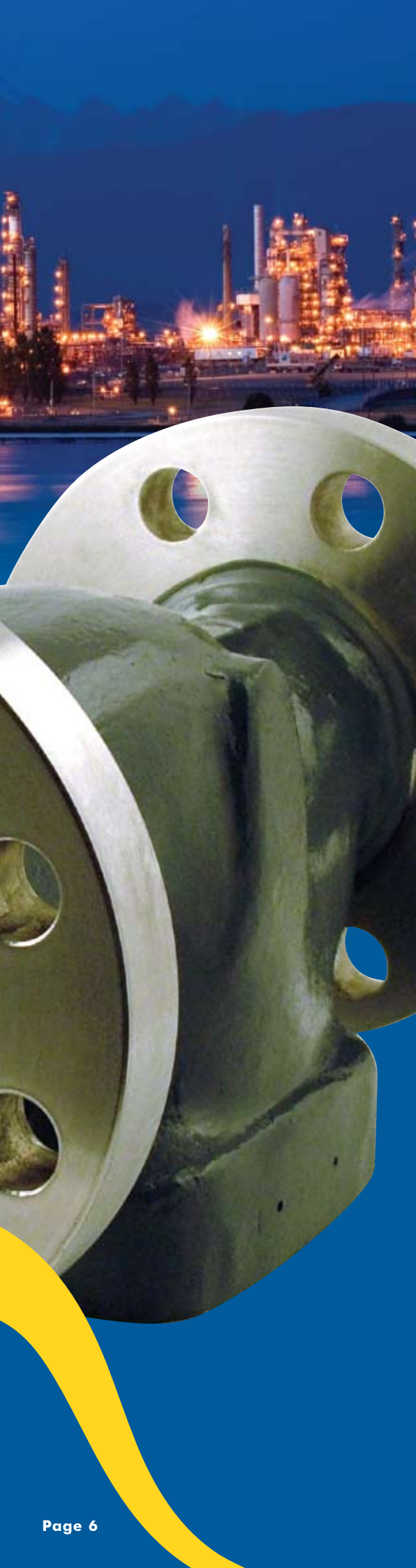

GFLO Trim Characteristic

Equal Percentage

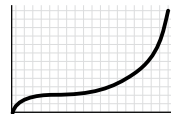
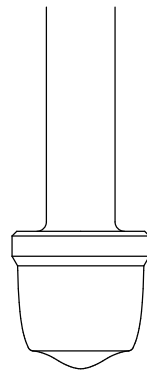

Linear

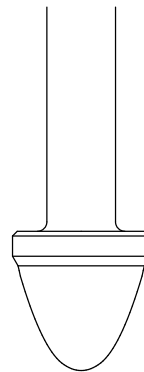

Quick Open

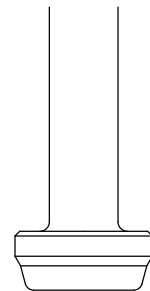

Trim Sizes

Each valve size features a large number of trim sizes for optimized process control.

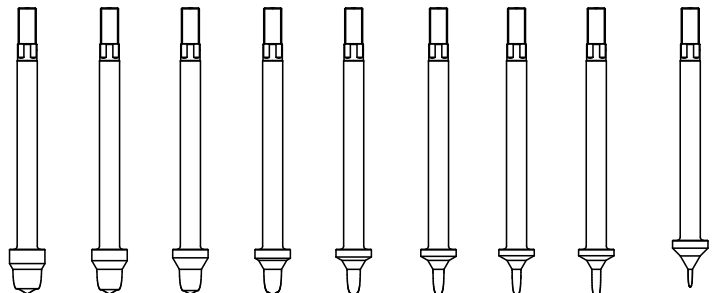

GFLO Trim



Trim

- Plug
- Seat
- Seat Retainer



Plug

- Solid one-piece construction
- Plug head is NOT screwed or pinned to stem
- Large heavy duty stem diameter
- High thrust capability
- Will not bend or buckle



Seat Ring

- Self aligning design
- Seat ring moves into perfect alignment with plug during assembly process.
- Clamped in seat (not screwed)
- Easy to remove for maintenance



Seat Retainer

- Firmly and securely clamps seat ring into position
- Large clearance between seat retainer and plug head
- Trim will not stick or seize in dirty service



GFLO Pressure Balanced Trim

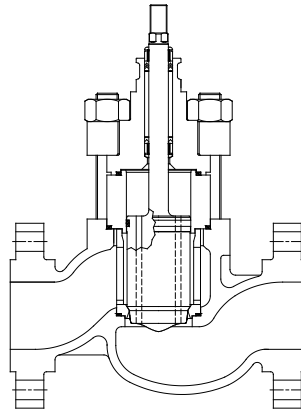

External Pressure
Balanced Sleeve

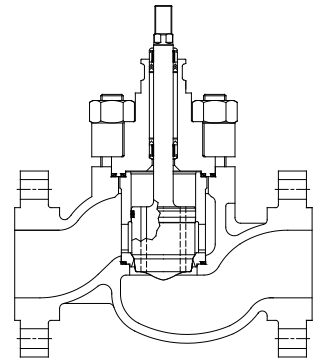

Standard Pressure
Balanced Sleeve



GFLO Bonnet Styles

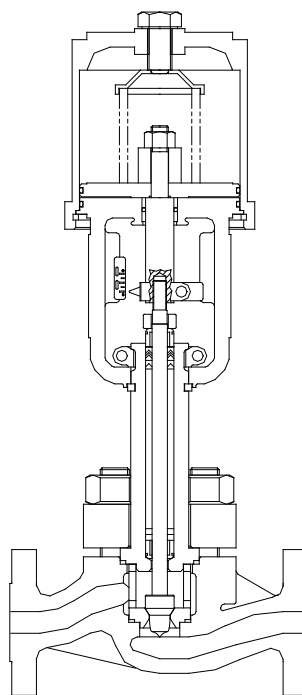

Extended

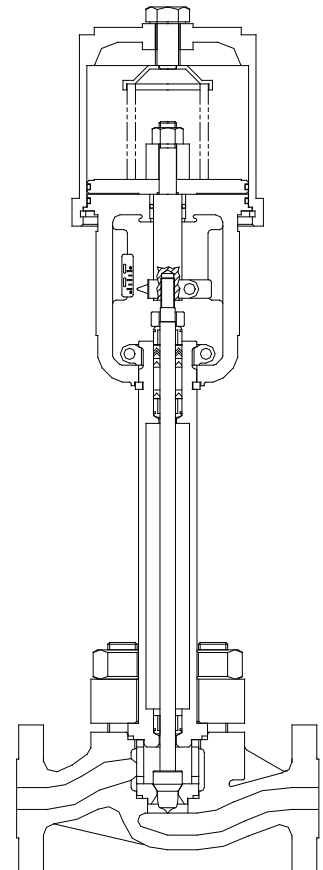

Cryogenic

GFLO Soft Goods



Gaskets

- PTFE
- Spiral Grafoil



Guides

- Glass Lined PTFE
- Grafoil
- Bronze
- Stellite

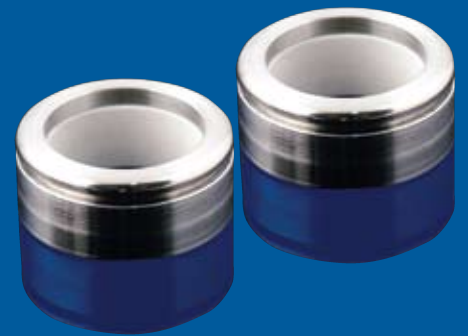

Stem Seal

- PTFE V-Ring
- Braided PTFE
- Braided Grafoil
- Low Fugitive Emission
- Bellows Seal

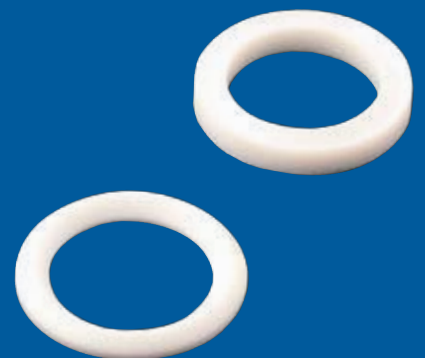



Pneumatic Spring Cylinder Actuator

- High thrust
- Double acting
- High throttling stiffness
- Permit flow under and flow over flow direction
- Eliminates the requirement for pressure balanced trim in many instances
- Field reversible fail closed to fail open and vice versa
- Three actuator sizes typically cover 95% of a plants requirements
- Minimal spare part requirements

Air to open (fail closed)

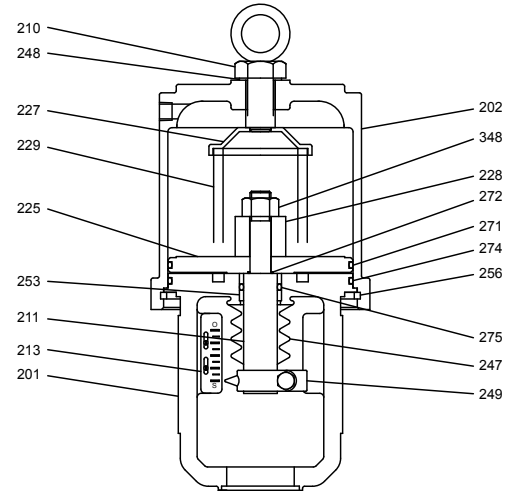

Air to close (fail open)

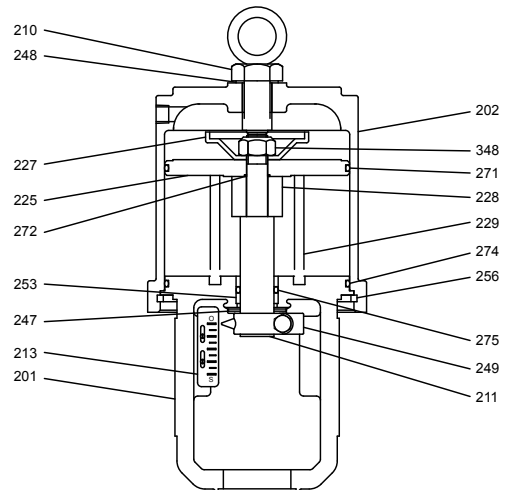

201	YOKE
202	CYLINDER
210	ADJUSTING SCREW
211	ACTUATOR STEM
213	STROKE PLATE
225	PISTON
227	SPRING BUTTON
228	ACTUATOR STEM SPACER
229	SPRING
247	STEM BELLOWS
248	ADJUSTING SCREW GASKET
249	STEM CLAMP
253	YOKE BUSH
256	RETAINING RING
271	PISTON O-RING
272	YOKE O-RING
274	PISTON STEM O-RING
275	ACTUATOR STEM O-RING
348	ACTUATOR STEM LOCK NUT

GFLO Ease of Maintenance

Top Entry Design

- Valve Trim can be inspected and removed without removing valve from pipeline

Clamped in Seat Ring

- Easy to remove as compared with screwed in seat rings.

Knife Edge Contact between Plug & Seat

- Seating surfaces can be repaired by simple machining process
- Lapping of the Plug and Seat is NOT required or recommended.

Yoke Clamps

- Actuator and yoke assembly is held securely in place by yoke clamps and bolting.
- Permits fast and easy removal of actuator and yoke from bonnet.
- Yoke clamp halves held in place by yoke clamp bolting
- Avoids disassembly problems and difficulty associated with corroded Yoke nuts.

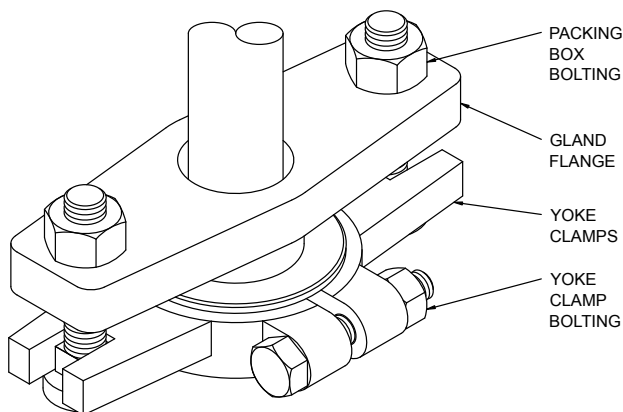

Minimal spare part requirements

- Reduced repair cost

High degree of parts interchangeability between valve sizes and pressure ratings

- Lower spare part inventory cost

Three actuator sizes typically cover 95% of all actuator requirements for both fail open and fail closed.

- Three Actuator Repair Kits typically cover 95% of a plants requirements.





Interchangeability

MASCOT GFLO control valves feature an exceptionally high degree of parts interchangeability between valve sizes and pressure ratings.

This high degree of parts interchangeability combined with GFLO's heavy duty industrial design and Extended Mean Time Between Planned Maintenance (MTBPM) truly makes GFLO the lowest total cost of ownership control valve.

Interchangeability									
Bonnet & Seat Gaskets									
Pressure Rating	Size								
	0.5"	0.75"	1.0"	1.5"	2.0"	3.0"	4.0"	6.0"	8.0"
CL150	Blue	Blue	Blue	Green	Green	Yellow	Light Blue	Grey	Yellow
CL300	Blue	Blue	Blue	Green	Green	Yellow	Light Blue	Grey	Yellow
CL600	Blue	Blue	Blue	Green	Green	Yellow	Light Blue	Grey	Yellow
Packing and Guides									
Pressure Rating	Valve Size								
	0.5"	0.75"	1.0"	1.5"	2.0"	3.0"	4.0"	6.0"	8.0"
CL150	Blue	Blue	Blue	Green	Green	Yellow	Light Blue	Orange	Purple
CL300	Blue	Blue	Blue	Green	Green	Yellow	Light Blue	Grey	Yellow
CL600	Blue	Blue	Blue	Green	Green	Yellow	Light Blue	Grey	Yellow
Seat Rings									
Pressure Rating	Valve Size								
	0.5"	0.75"	1.0"	1.5"	2.0"	3.0"	4.0"	6.0"	8.0"
CL150	Blue	Blue	Blue	Green	Green	Yellow	Light Blue	Grey	Yellow
CL300	Blue	Blue	Blue	Green	Green	Yellow	Light Blue	Grey	Yellow
CL600	Blue	Blue	Blue	Green	Green	Yellow	Light Blue	Grey	Yellow
Plugs									
Pressure Rating	Valve Size								
	0.5"	0.75"	1.0"	1.5"	2.0"	3.0"	4.0"	6.0"	8.0"
CL150	Blue	Blue	Blue	Green	Green	Yellow	Light Blue	Orange	Purple
CL300	Blue	Blue	Blue	Green	Green	Yellow	Light Blue	Grey	Yellow
CL600	Blue	Blue	Blue	Green	Green	Yellow	Light Blue	Grey	Yellow
Actuators									
Pressure Rating	Valve Size								
	0.5"	0.75"	1.0"	1.5"	2.0"	3.0"	4.0"	6.0"	8.0"
CL150	25 Sq In	25 Sq In	25 Sq In	25 Sq In	25 Sq In	50 Sq In	50 Sq In	50 Sq In	100 Sq In
CL300	25 Sq In	25 Sq In	25 Sq In	25 Sq In	25 Sq In	50 Sq In	50 Sq In	100 Sq In	100 Sq In
CL600	25 Sq In	25 Sq In	25 Sq In	25 Sq In	25 Sq In	50 Sq In	50 Sq In	100 Sq In	100 Sq In

NB: Three Standard Actuator Sizes Typically Cover 95% of ALL Actuator Requirements (Fail Closed and Fail Open)



Codes and Standards

MASCOT control valves are designed, manufactured and tested in accordance with the following codes and standards.

ISO 9001	Quality Assurance System
ISA-75.01	Flow Equations for Sizing Control Valves
ISA-75.02	Control Valve Capacity Test Procedure
ISA-75.03	Face to Face Dimensions
ASME B16.34	Hydrostatic Testing of Control Valves
ASME/FCI 70-2	Control Valve Seat Leakage
ASME B16.5	Flange Dimensions
IEC 60534-8-3	Control Valve Aerodynamic Noise Prediction Method
ISA Guideline Compliant Specification – Control Valve Vibration and Erosion Limits	

Control Valve Sizing Equations

MASCOT Control Valves are sized in accordance with ISA-75.01 using the following equations

Calculating CV for Liquids

$$C_v = \frac{Q}{F_p} \sqrt{\frac{S_g}{\Delta P_a}}$$

Where: C_v = Valve sizing coefficient
 Q = Flow rate, gpm
 F_p = Piping geometry factor
 S_g = Specific gravity at flowing temperature
 ΔP_a = Allowable pressure drop across the valve for sizing, psi

The allowable pressure drop, ΔP_a , across the valve for calculating C_v , is the smaller of the actual ΔP and choked ΔP_{ch}

$$\Delta P = P_1 - P_2$$

$$\Delta P_{ch} = F_L^2 (P_1 - F_F P_v)$$

$$F_F = 0.96 - 0.28 \sqrt{\frac{S_g}{\Delta P_a}}$$

Where: P_1 = Upstream Pressure, psia
 P_2 = Downstream Pressure, psia
 F_L = Liquid pressure recovery factor
 F_F = Liquid critical pressure ratio factor
 P_v = Vapour pressure of the liquid at inlet temperature, psia
 S_g = Specific gravity at flowing temperature

Calculating CV for Gases

$$C_v = \frac{W}{19.3 F_p P_1 Y} \sqrt{\frac{T_1 Z}{x M_w}}$$

OR

$$C_v = \frac{Q}{7320 F_p P_1 Y} \sqrt{\frac{M_w T_1 Z}{x}}$$

Where: C_v = Valve sizing coefficient
 W = Gas flow rate, lb/hr
 Q = Gas flow in standard ft³/hr (SCFH)
 M_w = Molecular weight
 F_p = Piping geometry factor
 P_1 = Upstream absolute pressure, psia
 T_1 = Absolute upstream temperature °R = (°F + 460°)
 x = Pressure drop ratio
 Y = Expansion factor
 Z = Compressibility factor



GFLO Materials of Construction

Body Material			
Material	ASTM Material Specification	Temperature Limit Guideline (Deg C)	
		Lower	Upper
Carbon Steel	A216 Grade WCB	-29	537
Carbon Steel (Low Temp)	A352 Grade LCB	-45	343
1 1/4 Chrome - 1/2 Moly	A217 Grade WC6	-28	537
2 1/4 Chrome - 1 Moly	A217 Grade WC9	-28	565
304 SS	A351 Grade CF8	-253	815
316 SS	A351 Grade CF8M	-253	815
Duplex SS	A890	-50	300
Monel 400	A494-M30C	-198	482
Hastelloy B	N-7M	-200	870
Hastelloy C	CW-6M	-200	1090
Zirconium	702C	*	*
Titanium	B367 Grade 3	-28	315

Trim Material		
Material	Temperature Limit Guideline (Deg C)	
	Lower	Upper
316 SS	-253	315
304 SS	-253	315
316 SS / Alloy 6	-84	815
416 SS	-28	426
440 SS	-28	426
Bronze	-253	232
Monel 400	-240	482
Alloy 20	*	*
Duplex SS	-50	300
Hastelloy B & C	-200	870/1090
Inconel	-240	648
Zirconium	*	*
Titanium	-28	315
Tungsten Carbide	*	*
Ceramic	*	*

* Application dependent; contact MASCOT for more information.

Bolting Material			
Bolt Material	Nut Material	Temperature Limit (Deg C)	
		Lower	Upper
ASTM A193 Gr B7	ASTM A194 Gr 2H	-28	426
ASTM A193 Gr B7	ASTM A194 Gr 7	427	537
ASTM A193 Gr B16	ASTM A194 Gr 7	538	565
ASTM A193 Gr B16	ASTM A194 Gr 4	538	593
ASTM A320 Gr B8	ASTM A194 Gr 8	-252	37
ASTM A193 Gr B8	ASTM A194 Gr 8	37	815
ASTM A193 Gr B8M	ASTM A194 Gr 8M	37	815

Gasket Material				
Material	Type	Temperature Limit (Deg C)		Pressure Limit
		Lower	Upper	
PTFE	Flat	-128	176	Temperature Dependant
Grafoil	Spiral	-252	537	431 BarG

Packing Material						
Material	Pressure Rating	Standard Bonnet Temperature Limit (Deg C)		Extended Bonnet Temperature Limit (Deg C)		Pressure Limit
		Lower	Upper	Lower	Upper	
TFE V-Ring	CL150 - CL600	-28	232	-101	315	Temperature Dependant
	CL900 - CL1500	-28	232	-101	371	Temperature Dependant
	CL2500	-28	232	-101	371	Temperature Dependant
Braided PTFE	CL150 - CL600	-28	260	-101	315	Temperature Dependant
	CL900 - CL1500	-28	260	-101	371	Temperature Dependant
	CL2500	-28	260	-101	371	Temperature Dependant
Garlock 1298 (AFPI)	CL150 - CL600	-28	398	-28	648	Body Rating
	CL900 - CL1500	-28	426	-28	648	Body Rating
	CL2500	-28	426	-28	648	Body Rating
Grafoil	CL150 - CL600	-28	398	-28	815	Body Rating
	CL900 - CL1500	-28	426	-28	815	Body Rating
	CL2500	-28	426	-28	815	Body Rating

Packing Material	Pressure Rating	Cryogenic Extension Bonnet (mm)	Temperature Limit (Deg C)	Pressure Limit
TFE V-Ring	CL150 - CL600	375	-195	Body Rating
Braided PTFE	CL150 - CL600	450	-212	Body Rating
Braided PTFE	CL150 - CL600	600	-252	Body Rating



GFLO Cv Tables

Valve Type:		GFLO											
Pressure Rating:		CL150 - CL600											
Characteristic:		Equal Percentage											
Size	Trim No	Stroke	FL	Cv at Percent Travel									
				100	90	80	70	60	50	40	30	20	10
0.50	0.50	0.75	0.83	5.10	4.70	3.70	2.60	1.90	1.40	0.91	0.56	0.33	0.25
	0.38	0.75	0.82	3.80	3.40	2.50	1.70	1.20	0.86	0.50	0.31	0.19	0.13
	0.31	0.75	0.81	2.90	2.60	1.80	1.20	1.00	0.59	0.34	0.22	0.15	0.10
	0.25A	0.75	0.81	2.00	1.60	1.10	0.81	0.56	0.37	0.23	0.14	0.09	0.06
	0.25B	0.75	0.81	1.30	1.00	0.63	0.40	0.25	0.16	0.10	0.05	0.03	0.02
	0.12A	0.50	0.81	0.46	0.45	0.38	0.27	0.17	0.10	0.07	0.04	0.03	0.02
1.00	0.81	0.75	0.87	15.50	14.10	11.20	8.00	4.90	3.30	2.80	2.10	1.60	1.10
	0.72	0.75	0.85	13.40	11.70	8.90	6.10	3.90	3.10	2.30	1.60	1.10	0.70
	0.62	0.75	0.83	10.20	8.70	6.50	4.20	2.70	2.30	1.50	1.00	0.61	0.35
	0.50	0.75	0.82	6.50	5.70	4.40	2.90	1.90	1.50	1.09	0.72	0.46	0.26
	0.38	0.75	0.82	4.10	3.40	2.30	1.50	1.30	0.84	0.51	0.33	0.22	0.14
	0.31	0.75	0.81	2.90	2.40	1.60	1.10	0.92	0.61	0.35	0.20	0.14	0.09
	0.25A	0.75	0.81	1.90	1.50	1.10	0.83	0.56	0.31	0.21	0.13	0.08	0.06
	0.25B	0.75	0.81	1.30	1.00	0.63	0.40	0.25	0.16	0.10	0.06	0.04	0.03
1.50	0.12A	0.50	0.81	0.47	0.45	0.29	0.22	0.16	0.11	0.08	0.05	0.03	0.02
	1.25	1.00	0.86	32.00	29.00	21.00	14.00	9.40	6.50	4.40	3.00	2.00	1.40
	1.00	0.75	0.85	24.00	20.00	14.00	9.10	6.10	4.20	2.80	1.90	1.30	0.88
	0.81	0.75	0.82	18.00	13.00	8.90	6.00	4.10	2.80	1.90	1.30	0.86	0.59
	0.62	0.75	0.82	11.00	7.70	5.20	3.60	2.40	1.70	1.10	0.76	0.51	0.35
	0.38	0.75	0.79	4.20	2.80	1.90	1.30	0.88	0.60	0.40	0.27	0.18	0.13
2.00	1.62	1.50	0.89	54.00	47.00	33.00	23.00	16.00	11.00	7.50	5.10	3.40	2.30
	1.25	1.00	0.87	35.00	31.00	22.00	14.00	9.60	6.60	4.40	3.00	2.00	1.40
	1.00	0.75	0.83	25.00	21.00	15.00	9.30	6.20	4.20	2.90	1.90	1.30	0.88
	0.81	0.75	0.82	19.00	14.00	9.00	6.00	4.10	2.80	1.90	1.30	0.86	0.58
	0.62	0.75	0.79	11.00	7.80	5.30	3.60	2.40	1.70	1.10	0.76	0.51	0.35
3.00	0.38	0.75	0.79	4.20	2.90	1.90	1.30	0.88	0.60	0.40	0.27	0.18	0.13
	2.62	2.00	0.87	128.0	106.0	86.0	65.0	41.0	28.0	19.0	13.0	9.0	6.1
	2.00	1.50	0.83	81.0	67.0	56.0	42.0	25.0	17.0	11.0	7.7	5.2	3.5
	1.62	1.50	0.81	62.0	52.0	35.0	24.0	16.0	11.0	7.5	5.1	3.5	2.3
4.00	1.25	1.00	0.78	38.0	33.0	23.0	14.0	9.7	6.6	4.5	3.0	2.0	1.4
	3.50	2.50	0.86	210.0	180.0	150.0	119.0	74.0	50.0	34.0	23.0	16.0	11.0
	2.62	2.00	0.82	137.0	115.0	101.0	68.0	42.0	29.0	20.0	13.0	9.0	6.1
	2.25	2.00	0.82	106.0	90.0	69.0	41.0	28.0	21.0	14.0	9.8	6.6	4.6
6.00	1.62	1.50	0.79	70.0	54.0	36.0	24.0	16.0	11.0	7.5	5.1	3.5	2.3
	5.00	3.00	0.85	431.0	378.0	309.0	238.0	179.0	103.0	69.0	48.0	32.0	22.0
	3.50	2.50	0.83	261.0	210.0	163.0	128.0	77.0	51.0	35.0	24.0	16.0	11.0
	3.00	2.00	0.81	192.0	154.0	121.0	102.0	61.0	38.0	26.0	17.0	12.0	8.0
8.00	2.62	2.00	0.78	152.0	121.0	100.0	70.0	42.0	29.0	20.0	13.0	9.0	6.1
	6.25	4.00	0.86	683.0	593.0	477.0	367.0	251.0	159.0	109.0	75.0	51.0	34.0
	5.00	3.00	0.80	505.0	419.0	330.0	253.0	187.0	105.0	70.0	48.0	32.0	22.0
	3.50	2.50	0.83	272.0	217.0	172.0	132.0	78.0	51.0	35.0	24.0	16.0	11.0
10.00	2.62	2.00	0.82	154.0	126.0	109.0	70.0	43.0	29.0	20.0	13.0	9.0	6.1
	8.00	4.00	0.85	1120.0	990.0	820.0	646.0	486.0	342.0	176.0	122.0	83.0	57.0
	6.25	4.00	0.83	800.0	661.0	515.0	403.0	261.0	162.0	110.0	75.0	51.0	34.0
12.00	5.00	3.00	0.82	538.0	434.0	342.0	278.0	192.0	106.0	71.0	48.0	33.0	22.0
	9.50	4.00	0.85	1470.0	1350.0	1190.0	980.0	750.0	555.0	396.0	177.0	117.0	79.0
	7.38	4.00	0.83	1080.0	910.0	730.0	555.0	433.0	250.0	154.0	105.0	70.0	48.0
	6.25	4.00	840.0	680.0	526.0	409.0	263.0	163.0	111.0	75.0	51.0	34.0	



GFLO Cv Tables

Valve Type:		GFLO											
Pressure Rating:		CL900 - CL1500											
Characteristic:		Equal Percentage											
Size	Trim No	Stroke	FL	Cv at Percent Travel									
				100	90	80	70	60	50	40	30	20	10
1.00	0.81	0.75	0.87	9.90	8.80	7.30	5.40	3.90	2.70	1.90	1.30	0.86	0.58
	0.72	0.75	0.85	9.30	8.00	6.10	4.50	3.20	2.20	1.50	1.00	0.68	0.46
	0.62	0.75	0.83	8.30	6.60	4.90	3.50	2.40	1.70	1.10	0.76	0.51	0.35
	0.50	0.75	0.82	6.40	4.60	3.30	2.30	1.60	1.10	0.72	0.49	0.33	0.22
	0.38	0.75	0.82	4.00	2.80	1.90	1.30	0.89	0.60	0.41	0.27	0.18	0.13
	0.31	0.75	0.81	2.90	2.00	1.30	0.91	0.61	0.41	0.28	0.19	0.13	0.09
	0.25A	0.75	0.81	1.90	1.30	0.86	0.58	0.39	0.27	0.19	0.12	0.08	0.06
	0.25B	0.75	0.81	1.10	0.83	0.60	0.36	0.23	0.16	0.10	0.07	0.06	0.05
	0.12A	0.50	0.81	0.57	0.36	0.22	0.15	0.11	0.07	0.05	0.04	0.03	0.02
	1.50	1.25	1.00	0.86	23.0	22.0	18.0	13.0	9.4	6.5	4.5	3.0	2.1
1.00		0.75	0.85	19.0	18.0	14.0	9.1	6.2	4.2	2.9	1.9	1.3	0.9
0.81		0.75	0.83	16.0	13.0	8.8	6.0	4.1	2.8	1.9	1.3	0.9	0.6
0.62		0.75	0.82	11.0	7.7	5.3	3.6	2.5	1.7	1.1	0.8	0.5	0.4
0.38		0.75	0.79	4.2	2.9	1.9	1.3	0.9	0.6	0.4	0.3	0.2	0.1
0.31		0.75	0.81	2.9	2.0	1.3	0.91	0.61	0.41	0.28	0.19	0.13	0.09
2.00	1.62	1.50	0.89	38.0	36.0	29.0	22.0	16.0	11.0	7.5	5.1	3.5	2.3
	1.25	1.00	0.87	30.0	28.0	21.0	14.0	9.7	6.6	4.5	3.0	2.1	1.4
	1.00	0.75	0.83	24.0	20.0	15.0	9.4	6.3	4.3	2.9	1.9	1.3	0.9
	0.81	0.75	0.82	18.0	14.0	9.1	6.1	4.1	2.8	1.9	1.3	0.9	0.6
	0.62	0.75	0.79	11.0	7.9	5.3	3.6	2.5	1.7	1.1	0.8	0.5	0.4
	0.38	0.75	0.79	4.3	2.9	1.9	1.3	0.9	0.6	0.4	0.3	0.2	0.1
3.00	2.62	2.00	0.87	99.0	89.0	77.0	63.0	41.0	29.0	20.0	13.0	9.1	6.1
	2.00	1.50	0.83	74.0	64.0	55.0	42.0	25.0	17.0	11.0	7.8	5.2	3.5
	1.62	1.50	0.81	60.0	52.0	36.0	24.0	17.0	11.0	7.6	5.1	3.5	2.3
	1.25	1.00	0.78	38.0	34.0	23.0	14.0	9.8	6.7	4.5	3.0	2.1	1.4
4.00	3.50	2.50	0.86	175.0	159.0	140.0	117.0	75.0	51.0	35.0	24.0	16.0	11.0
	2.62	2.00	0.83	130.0	113.0	101.0	69.0	43.0	29.0	20.0	13.0	9.1	6.1
	2.25	2.00	0.82	106.0	91.0	71.0	42.0	29.0	22.0	15.0	9.8	6.6	4.6
	1.62	1.50	0.79	72.0	55.0	37.0	25.0	17.0	11.0	7.6	5.1	3.5	2.3
6.00	5.00	3.00	0.85	365.0	334.0	290.0	235.0	182.0	106.0	71.0	49.0	33.0	23.0
	3.50	2.50	0.83	254.0	210.0	167.0	132.0	79.0	52.0	35.0	24.0	16.0	11.0
	3.00	2.00	0.81	194.0	158.0	125.0	105.0	62.0	38.0	26.0	18.0	12.0	8.0
	2.62	2.00	0.78	156.0	125.0	103.0	72.0	43.0	29.0	20.0	13.0	9.1	6.1
8.00	6.25	4.00	0.86	571.0	522.0	448.0	362.0	256.0	164.0	112.0	76.0	51.0	35.0
	5.00	3.00	0.83	467.0	405.0	330.0	259.0	192.0	108.0	72.0	49.0	33.0	23.0
	3.50	2.50	0.82	278.0	222.0	177.0	135.0	80.0	52.0	35.0	24.0	16.0	11.0
	2.62	2.00	0.80	158.0	129.0	112.0	72.0	43.0	29.0	20.0	13.0	9.0	6.1



GFLO Cv Tables

Valve Type:		GFLO												
Pressure Rating:		CL2500												
Characteristic:		Equal Percentage												
Size	Trim No	Stroke	FL	Cv at Percent Travel										
				100	90	80	70	60	50	40	30	20	10	
1.00	0.72	0.75	0.85	8.40	7.40	5.80	4.40	3.10	2.20	1.50	1.00	0.68	0.46	
	0.62	0.75	0.83	7.60	6.30	4.80	3.50	2.40	1.70	1.10	0.76	0.51	0.35	
	0.50	0.75	0.82	6.10	4.50	3.30	2.30	1.60	1.10	0.72	0.49	0.33	0.22	
	0.38	0.75	0.82	4.00	2.80	1.90	1.30	0.89	0.60	0.41	0.27	0.18	0.13	
	0.31	0.75	0.81	2.90	2.00	1.30	0.91	0.61	0.41	0.28	0.19	0.13	0.09	
	0.25A	0.75	0.81	1.90	1.30	0.86	0.58	0.39	0.27	0.19	0.12	0.08	0.06	
	0.25B	0.75	0.81	1.10	0.83	0.60	0.36	0.23	0.16	0.10	0.07	0.06	0.05	
	0.12A	0.50	0.81	0.57	0.36	0.22	0.15	0.11	0.07	0.05	0.04	0.03	0.02	
1.50	1.00	0.75	0.85	16.0	15.0	12.0	8.6	6.0	4.2	2.9	1.9	1.3	0.9	
	0.81	0.75	0.83	14.0	12.0	8.4	5.9	4.1	2.8	1.9	1.3	0.9	0.6	
	0.62	0.75	0.82	10.0	7.4	5.2	3.6	2.5	1.7	1.1	0.8	0.5	0.4	
	0.38	0.75	0.79	4.2	2.9	1.9	1.3	0.9	0.6	0.4	0.3	0.2	0.1	
	2.00	1.00	0.87	24.0	23.0	19.0	13.0	9.5	6.6	4.5	3.0	2.1	1.4	
2.00	1.00	0.75	0.83	20.0	18.0	14.0	9.1	6.2	4.2	2.9	1.9	1.3	0.9	
	0.81	0.75	0.82	17.0	13.0	8.9	6.0	4.1	2.8	1.9	1.3	0.9	0.6	
	0.62	0.75	0.79	11.0	7.8	5.3	3.6	2.5	1.7	1.1	0.8	0.5	0.4	
	0.38	0.75	0.79	4.3	2.9	1.9	1.3	0.9	0.6	0.4	0.3	0.2	0.1	
	3.00	2.00	1.50	0.83	60.0	54.0	48.0	39.0	25.0	17.0	11.0	7.8	5.2	3.5
3.00	1.62	1.50	0.81	52.0	46.0	34.0	24.0	16.0	11.0	7.6	5.1	3.5	2.3	
	1.25	1.00	0.78	36.0	32.0	22.0	14.0	9.8	6.7	4.5	3.0	2.1	1.4	
	4.00	2.62	2.00	0.83	103.0	94.0	86.0	64.0	42.0	29.0	20.0	13.0	9.1	6.1
4.00	2.25	2.00	0.82	89.0	80.0	65.0	41.0	29.0	21.0	15.0	9.9	6.6	4.6	
	1.62	1.50	0.79	66.0	53.0	36.0	24.0	17.0	11.0	7.6	5.1	3.5	2.3	
	6.00	4.00	2.50	0.85	260.0	242.0	215.0	181.0	136.0	83.0	52.0	33.0	21.0	15.0
6.00	3.50	2.50	0.83	219.0	189.0	156.0	126.0	78.0	52.0	35.0	24.0	16.0	11.0	
	3.00	2.00	0.81	177.0	148.0	120.0	102.0	62.0	38.0	26.0	18.0	12.0	8.0	
	2.62	2.00	0.78	147.0	120.0	100.0	71.0	43.0	29.0	20.0	13.0	9.1	6.1	
8.00	5.00	4.00	0.86	450.0	304.0	206.0	139.0	94.0	64.0	43.0	29.0	20.0	13.0	



GFLO Dimensions and Weights

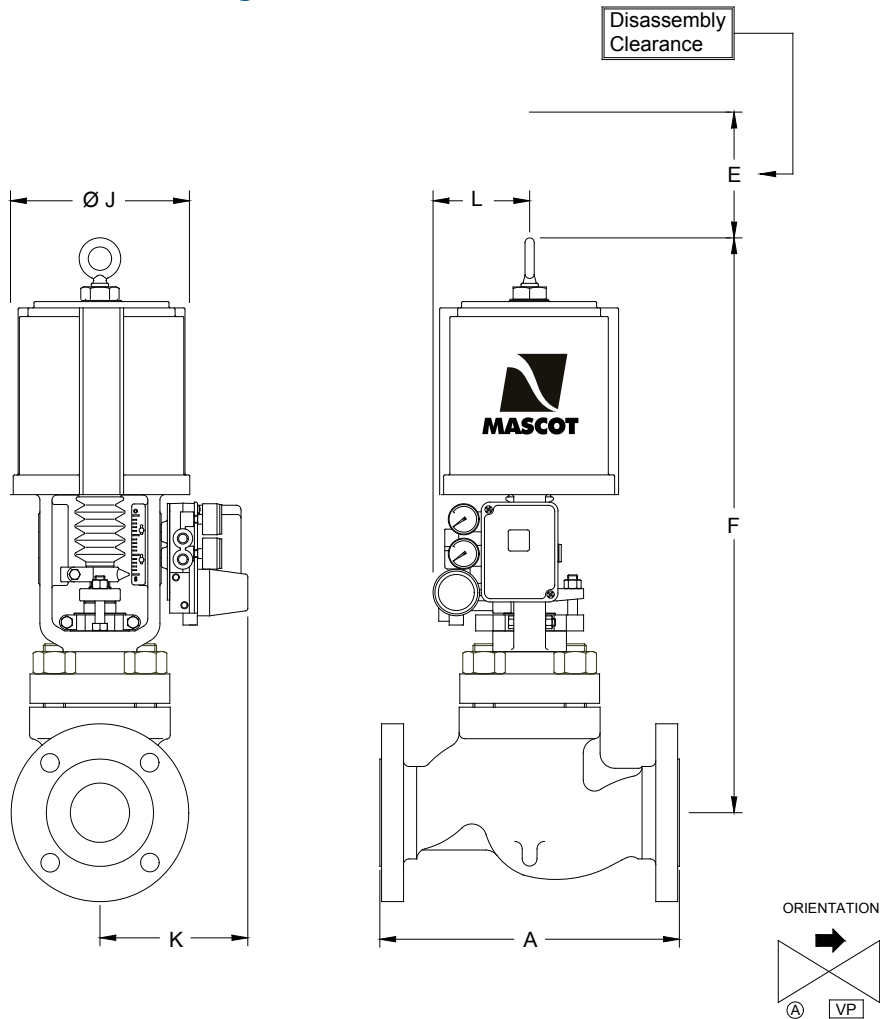

Dimensions
in m.m.

A ^{±2}	E	F ^{±30}	Ø J ^{±3}	K ^{±3}	L ^{±3}	Approximate Weight

Shipping Weights (Kg)

Body Size (In)	Body Size (NB)	Model	Pressure Rating					
			CL150	CL300	CL600	CL900	CL1500	CL2500
1.0	25	GFLO	23	23	23	45	55	68
1.5	40	GFLO	30	30	30	77	82	95
2.0	50	GFLO	34	34	34	91	100	136
3.0	80	GFLO	73	77	82	182	195	227
4.0	100	GFLO	110	114	121	268	277	427
6.0	150	GFLO	165	259	273	455	532	636
8.0	200	GFLO	268	359	378	500	600	791
10.0	250	GFLO	480	640	727	*	*	*
12.0	300	GFLO	581	769	899	*	*	*

Please Note: 1. Shipping Weights are based on standard actuator size and positioner only. Please contact MASCOT for shipping weights for valves with Oversize Actuators, Extended Bonnets, Handwheels etc.
* Contact MASCOT for more information



Body Size (In)	Body Size (NB)	Model	Rating	Actuator	A ± 2 mm	E mm	F ± 30 mm	ØJ ± 3 mm	K ± 3 mm	L ± 3 mm	Approx Weight Kg
1.0	25	GFLO	CL150	25	184	64	465	165	230	175	23
1.5	40	GFLO	CL150	25	222	102	501	165	230	175	30
2.0	50	GFLO	CL150	25	254	114	506	165	230	175	34
3.0	80	GFLO	CL150	50	298	147	700	230	228	168	73
4.0	100	GFLO	CL150	50	353	191	740	230	228	168	110
6.0	150	GFLO	CL150	50	451	254	782	230	228	168	165
8.0	200	GFLO	CL150	100	543	277	1002	318	304	155	268
10.0	250	GFLO	CL150	100	673	302	1044	318	304	155	480
12.0	300	GFLO	CL150	100	737	321	1044	318	304	155	581
1.0	25	GFLO	CL300	25	197	64	465	165	230	175	23
1.5	40	GFLO	CL300	25	235	102	501	165	230	175	30
2.0	50	GFLO	CL300	25	267	114	506	165	230	175	34
3.0	80	GFLO	CL300	50	318	147	700	230	228	168	77
4.0	100	GFLO	CL300	50	368	191	740	230	228	168	114
6.0	150	GFLO	CL300	100	473	254	997	318	304	155	259
8.0	200	GFLO	CL300	100	568	290	1046	318	304	155	359
10.0	250	GFLO	CL300	100	708	308	1046	318	304	155	640
12.0	300	GFLO	CL300	100	775	321	1097	318	304	155	769
1.0	25	GFLO	CL600	25	210	64	465	165	230	175	23
1.5	40	GFLO	CL600	25	251	102	501	165	230	175	30
2.0	50	GFLO	CL600	25	286	114	506	165	230	175	34
3.0	80	GFLO	CL600	50	337	147	700	230	228	168	82
4.0	100	GFLO	CL600	50	394	191	740	230	228	168	121
6.0	150	GFLO	CL600	100	508	254	997	318	304	155	273
8.0	200	GFLO	CL600	100	610	290	1046	318	304	155	378
10.0	250	GFLO	CL600	100	752	308	1046	318	304	155	727
12.0	300	GFLO	CL600	100	819	321	1097	318	304	155	899
1.0	25	GFLO	CL900 / CL1500	25	279	90	511	165	230	175	45 / 55
1.5	40	GFLO	CL900 / CL1500	50	330	141	747	230	228	168	77 / 82
2.0	50	GFLO	CL900 / CL1500	50	375	154	747	230	228	168	91 / 100
3.0	80	GFLO	CL900 / CL1500	100	460	216	975	318	304	155	182 / 195
4.0	100	GFLO	CL900 / CL1500	100	635	246	1002	318	304	155	268 / 277
6.0	150	GFLO	CL900 / CL1500	100	762	309	1100	318	304	155	455 / 532
8.0	200	GFLO	CL900 / CL1500	100	832	424	1159	318	304	155	500 / 600
1.0	25	GFLO	CL2500	25	305	90	541	165	230	175	68
1.5	40	GFLO	CL2500	50	381	141	747	230	228	168	95
2.0	50	GFLO	CL2500	50	400	154	747	230	228	168	136
3.0	80	GFLO	CL2500	100	660	211	1015	318	304	155	227
4.0	100	GFLO	CL2500	100	737	272	1054	318	304	155	427
6.0	150	GFLO	CL2500	100	864	344	1125	318	304	155	636
8.0	200	GFLO	CL2500	100	1022	451	1299	318	304	155	791



GFL0

High Performance Single Seated Globe Control Valve

Body type: 2way, 3way, angle & jacketed
 Size: 0.5" to 30.0"
 Pressure Class: . . . Up to ANSI CL 4500
 Body Material: . . . All castable alloys
 End Connections: . . Flanged, screwed, butt and socket welded
 Bonnet: Standard, extended, cryogenic & bellows sealed
 Guiding: Heavy duty double top stem
 Gland Packing: . . . PTFE, braided PTFE, grafoil, low fugitive emission
 Gaskets: PTFE, spiral grafoil
 Seat Ring: Clamped-in, self aligned
 Plug: Solid one piece construction with large stem diameter
 Characteristics: . . . Equal percentage, linear and on-off
 Special Trims: CAVFLO, MEGAFLO, GFL0 VC
 Actuator: Linear spring cylinder, fully field reversible
 Shut off class: With metal seat - ANSI IV or V and replaceable soft seat - ANSI VI



VFLO

High Performance V-Ball Control Valve

Body type: One-Piece VFLO Ball, straight-through
 Size: 0.5" to 18.0"
 Pressure Class: . . . Up to ANSI CL 900
 Body Material: . . . All castable alloys
 End Connections: . . Flangeless, flanged (integral and separable flange)
 Gland Packing: . . . PTFE, braided PTFE, grafoil
 Seat Ring: Clamped-in, self aligned, bi-directional
 Ball: Segmented V-notch ball, reduces clogging, shearing action fibrous fluids
 Shaft: Splined-No lost motion or dead band
 Characteristics: . . . Equal percentage, linear and on-off
 Rangeability: 300:1
 Actuator: Rotary spring cylinder, fully field reversible
 Shut off class: With metal seat - ANSI IV and replaceable soft seat - ANSI VI



DISKFLO

High Performance Wafer style Butterfly Control Valve

Body type: Wafer, light in weight, provides large flow and minimum pressure drop
 Size: 2.0" to 42.0"
 Pressure Class: . . . Up to ANSI CL 1500
 Body Material: . . . All castable alloys
 End Connections: . . Wafer, lugged, flanged
 Gland Packing: . . . PTFE, braided PTFE, grafoil
 Seat Ring: Clamped-in, self aligned
 Disc: Double eccentric cammed
 Shaft: Splined no lost motion or dead band
 Characteristics: . . . Equal percentage, linear and on-off
 Actuator: Rotary spring cylinder, fully field reversible
 Shut off class: With metal seat - ANSI IV and replaceable soft seat - ANSI VI



SEVERE SERVICE

Cavitation, Noise Abatement, Velocity Control Trim

Applications:

- Anti-cavitation trims
- Noise attenuation trims
- Multistage "velocity control" anti-cavitation
- Trims for liquid applications
- Multistage "velocity control" noise attenuating trims
- Choke applications

MASCOT Industrial

15A Randor Street Campbellfield, Victoria 3061 Australia

Tel: +61 3 9357 6555 | Fax: +61 3 9357 6566 | Email: sales@mascot-industrial.com | Web: www.mascot-industrial.com

The contents of this brochure are provided for informational purposes only. Whilst every effort has been made to ensure the accuracy of the information and specifications provided, they are not to be construed as warranties or guarantees, express or implied, regarding any matter in relation to this product. MASCOT Industrial reserves the right to modify or improve designs and as such the information and specifications provided in this brochure are subject to change without notice. MASCOT Industrial does not accept responsibility for the selection, use and maintenance of any product. Responsibility for the selection, use and maintenance of any product remains with the purchaser and end user.